



ETA-Danmark A/S
Göteborg Plads 1
DK-2150 Nordhavn
Tel. +45 72 24 59 00
Fax +45 72 24 59 04
Internet www.etadanmark.dk

Authorised and notified according
to Article 29 of the Regulation (EU)
No 305/2011 of the European
Parliament and of the Council of 9
March 2011

MEMBER OF EOTA



European Technical Assessment ETA-18/1001 of 2018/12/17

I General Part

Technical Assessment Body issuing the ETA and designated according to Article 29 of the Regulation (EU) No 305/2011: ETA-Danmark A/S

Trade name of the construction product:

HFB Fixing for GRC and concrete stone panels

Product family to which the above construction product belongs:

Fastener of external wall claddings

Manufacturer:

HFB Engineering GmbH
Zschortauer Straße 42
D - 04129 Leipzig
Telephone +49 0341/5636309
Internet www.gfb-hfb.de

Manufacturing plant:

HFB Engineering GmbH
Zschortauer Straße 42
D - 04129 Leipzig

This European Technical Assessment contains:

11 pages including 6 Annexes which form an integral part of the document

This European Technical Assessment is issued in accordance with Regulation (EU) No 305/2011, on the basis of:

EAD 330030-00-06.01 – Fastener of external wall claddings

This version replaces:

Translations of this European Technical Assessment in other languages shall fully correspond to the original issued document and should be identified as such.

Communication of this European Technical Assessment, including transmission by electronic means, shall be in full (excepted the confidential Annex(es) referred to above). However, partial reproduction may be made, with the written consent of the issuing Technical Assessment Body. Any partial reproduction has to be identified as such.

II SPECIFIC PART OF THE EUROPEAN TECHNICAL ASSESSMENT

1 Technical description of product and intended use

Technical description of the product

The HFB Fixing for Glassfibre Reinforced Concrete (GRC) and concrete stone panels is a concreted sleeve for the backside of façade plates, made of manufactured glass fibre reinforced concrete or fibre-modified artificial stone. The façade plates with backside fixing by the concreted sleeve may be used for external wall claddings, ventilated and rear. Each façade plate shall be fixed technically strain-free with four anchors in a rectangular arrangement via individual agraffes on a capable substructure.

The system consists of 2 parts – an L flange nut M8 and an anchor sleeve with an expansion part of an inside M8 thread and a rolled plate of stainless steel with material number 1.4404 according to EN 10088.

The dimensions of the anchor are given in annex A. The anchor is installed into an undercut drill hole and by driving-in the screw it is placed form-fitted and deformation-controlled.

The façade panels consist of a concrete matrix based on a white cement CEM I 52,5 R and defined content of alkali-resistant glass fibres.

In the basic recipe "creme white" 0.04 % by mass related to the cement content is added. The recipe counts as almost unpigmented and is thus regarded as reference.

The colours grey (0.3 % by mass of pigment) and anthracite (3 % by mass of pigment) contain black pigments. Anthracite 3 % by mass is the highest pigment content used by HFB Engineering GmbH. The effect of the pigments on the loadbearing behaviour has been investigated with the result that there is no reduction because of the pigmentation.

The concrete/glass fibre façade panels have the following characteristics:

E-Module [N/mm ²]	10.000
Thermal Expansion (/K)	1-1,5 × 10 ⁻⁵
5% Fractile bending resistance [N/mm ²]	2,9
Specific weight [g/cm ³]	2,20
Resistance to water [%]	0,01
Frost resistance	Yes

For the installed anchor see figure in Annex A1.

2 Specification of the intended use in accordance with the applicable EAD

The HFB Fixing for GRC and concrete stone panels is intended to be used for the rear fixing of façade panels made from glass fibre reinforced concrete or fibre modified artificial stone. For which requirements for mechanical resistance and stability in the sense of the Basic Works Requirements 1 of Regulation 305/2011 shall be fulfilled. The façade panels shall correspond to the drawings and specifications of this European Technical Assessment. The intended use specifications of the product are detailed in the Annex B1.

The façade panels with rear fixing by the anchor may only be used for rear ventilated front curtain walls. Each façade panel shall be fixed technically strain-free with at least four anchors in a rectangular arrangement via single agraffes on a capable substructure (for small panels or small fitted pieces, differential or fill- in pieces the number and position of the anchors shall be chosen constructively).

The anchor may be used in structures subject to dry internal conditions and also in structures subject to external atmospheric exposure (including industrial and marine environment), if no particular aggressive conditions exist. Such particular aggressive conditions are e.g. permanent, alternating immersion in seawater or the splash zone of seawater, chloride atmosphere of indoor swimming pools or atmosphere with extreme chemical pollution (e.g. in desulphurisation plants or road tunnels where de-icing materials are used).

The provisions made in this European Technical Assessment are based on an assumed working life of the anchor of 50 years.

The indications given on the working life cannot be interpreted as a guarantee given by the producer or Assessment Body, but are to be regarded only as a means for choosing the right products in relation to the expected economically reasonable working life of the works.

3 Performance of the product and references to the methods used for its assessment

Characteristic	Assessment of characteristic
3.1 Mechanical resistance and stability (BWR1)	
Characteristic load bearing capacity and displacements	The anchor corresponds to the drawings and specifications given in Annex A2-A3. The characteristic material values, dimensions and tolerances of the anchor not indicated in Annex A2-A3 shall correspond to the respective values laid down in the technical documentation of this European Technical Assessment.
Durability	The characteristic values for the design of the façade panels with rear fixing by the anchor are given in Annex C1-C2. The anchors are made from stainless steel (material no. 1.4401).
3.4 Safety in case of fire (BWR2)	
Reaction to fire	The anchors are made from steel classified as Euroclass A1 in accordance with EN 13501-1 and Commission Delegated Regulation 2016/364

4 Attestation and verification of constancy of performance (AVCP)

4.1 AVCP system

According to the decision 97/161/EC the European Commission, the system(s) of assessment and verification of constancy of performance (see Annex V to Regulation (EU) No 305/2011) is 2+.

5 Technical details necessary for the implementation of the AVCP system, as foreseen in the applicable EAD

Technical details necessary for the implementation of the AVCP system are laid down in the control plan deposited at ETA-Danmark prior to CE marking

Issued in Copenhagen on 2018-12-17 by



Thomas Bruun
Managing Director, ETA-Danmark

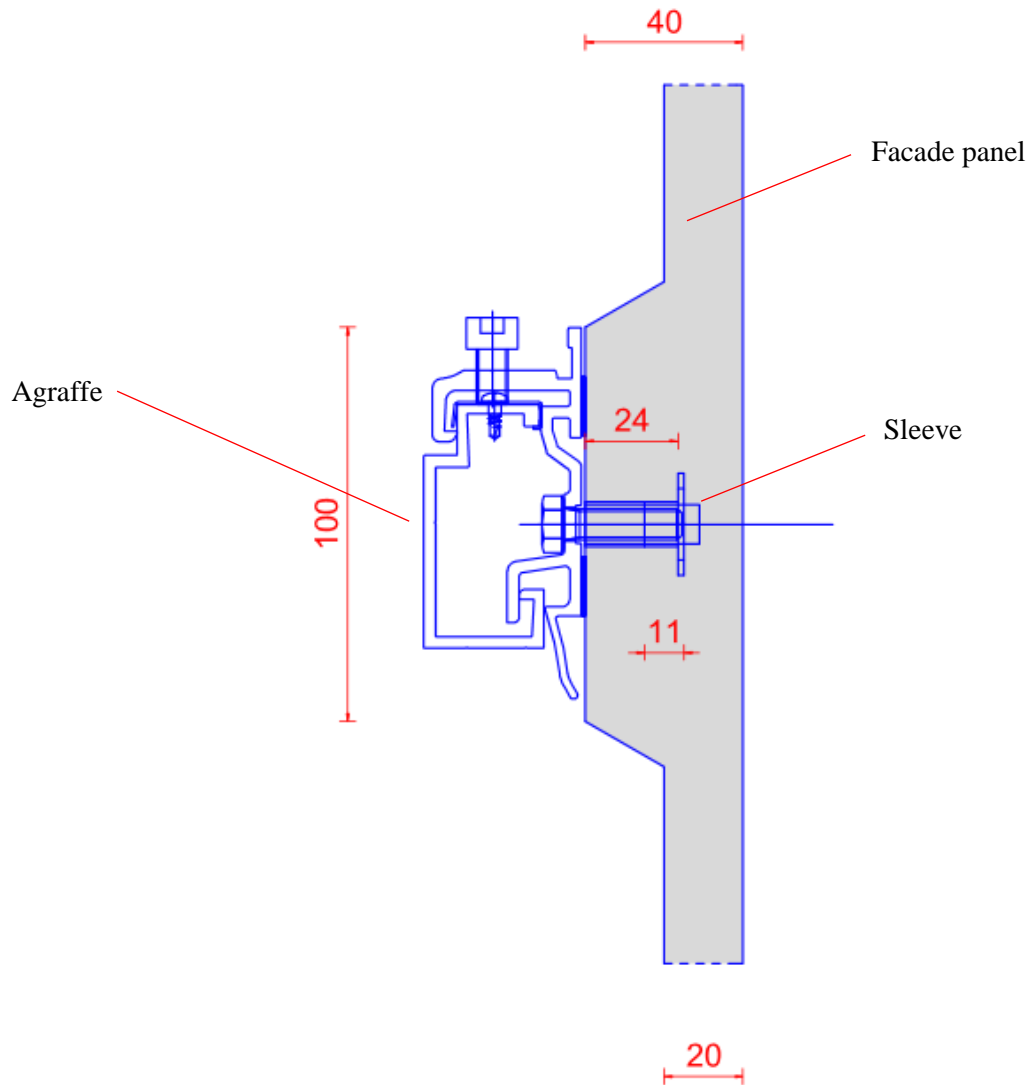

HFB Fixing for GRC and concrete stone panels

Product and intended use

Annex A1
of European
Technical Assessment
ETA-18/1001

Anchors sleeve dimension

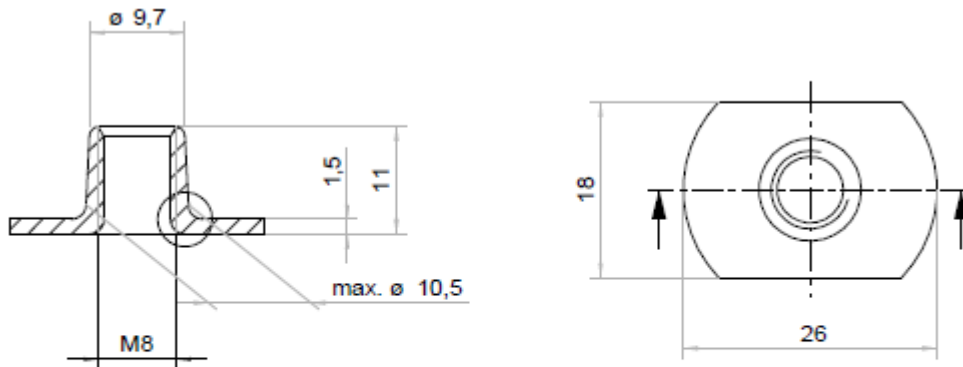

material: 1.4404

L-Flanschmutter M8-A4

<i>Characteristic values of installation</i>		M8
Thickness of facade plate	d [mm] =	20 -0,5/+1,0
Embedment depth / drill hole depth	h_s =	24
Nominal drill hole diameter	$\varnothing d_0$ [mm] =	M8
Thickness of agraffe material	t_{fix} [mm] =	≥ 2
Threaded length of screw	c [mm] =	10 ($h_s + t_{fix} = 24 + t_{fix}$)

HFB Fixing for GRC and concrete stone panels

Parts of anchor and characteristic values for anchor installation

Annex A2
of European
Technical Assessment
ETA-18/1001

Geometry of the drill hole

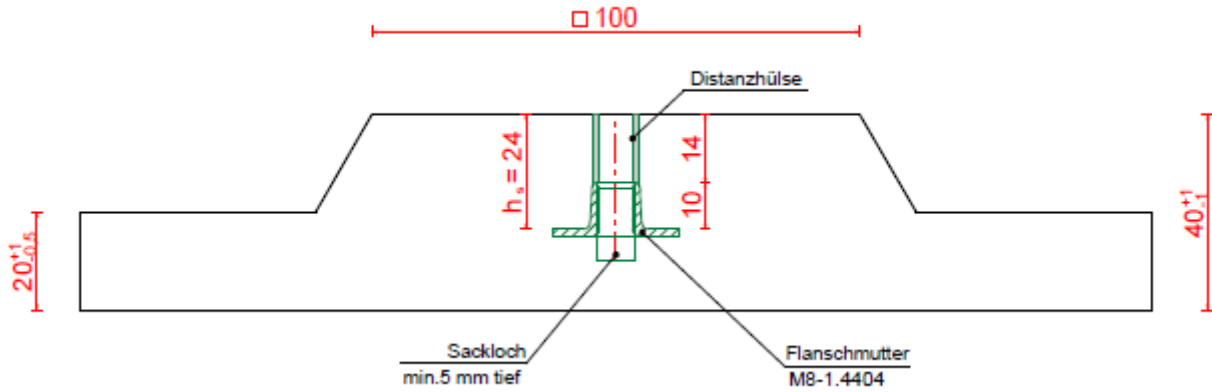

Position of factory installed threaded sleeve

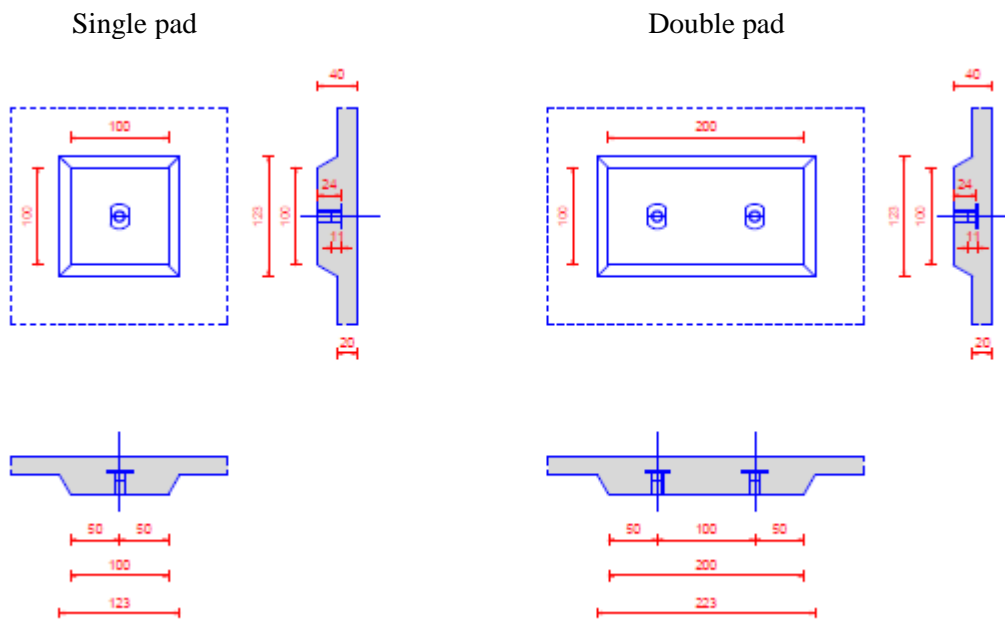

HFB Fixing for GRC and concrete stone panels

Drill hole dimensions
Setting tools and testing equipment

Annex A3
of European
Technical Assessment
ETA-18/1001

Use:

The anchors are intended to be used for anchorages for which requirements for mechanical resistance and stability in the sense of the Basic Requirements 1 of Regulation 305/2011 (EU) shall be fulfilled and failure of anchorages made with these products would compromise the stability of the works, cause risk to human life and/or lead to considerable economic consequences.

Use conditions (Environmental conditions):

Elements made of and stainless steel may be used in structures subject to the following conditions:

- Internal dry conditions
- Dry internal conditions, external atmospheric exposure (including industrial and marine environment) or exposure in permanently damp internal conditions if no particular aggressive conditions exist.
- dry internal conditions, external atmospheric exposure, in permanently damp internal conditions or in other particular aggressive conditions - e.g. permanent, alternating immersion in seawater, splash zone of seawater, chloride atmosphere of indoor swimming pools or atmosphere with chemical pollution (e.g. in desulphurization plants or road tunnels where de-icing materials are used).

Installation:

- The Glassfibre Reinforced Concrete (GRC) and concrete stone façade panels correspond to the drawings and specifications of the annexes. The characteristic material values, dimensions and tolerances of the façade panels not indicated in the annexes shall correspond to the respective values laid down in the technical documentation of this European Technical Assessment.
- The threaded sleeve is factory-injected into the partially 40 mm thickened pads. It is not necessary to drill holes at construction site.
- The characteristic values of installation and their definition shall be taken from annex A2.
- Each façade panel is fixed with at least four anchors in rectangular arrangement via single agraffes to the substructure; the substructure is constructed such that the façade panels are fixed technically strain - free via skids (loose bearings) and one fixed bearing.
- The façade panels are arranged in a "reclined" or "upright" position, they also may be fixed at façade soffits.
- Two fixing points of the façade panel are designed such that they are able to carry the dead load of the façade panel.
- The loadbearing profiles are arranged symmetrically. The arrangement of the agraffes ensures a symmetric introduction of the load into the substructure.
- When using agraffes on horizontal loadbearing profiles the fixing points of a façade panel situated horizontally at the same height are fastened in each case to the same loadbearing profile.
- The façade panels have not been assessed for use to transmit impact loads or for guard rail.
- Joint construction between the façade panels is done by a joint filler or is kept open. It is ensured that additional stresses (e.g. by temperature) do not lead to important additional loadings.

Proposed design methods:

The design values of the actions shall be calculated on basis of EN 1990 in consideration of the existing loads. The combinations of actions shall be equal to EN 1990. The actions shall be specified according to EN 1991-1-1 to EN 1991-1-7. The typical fundamental combination for façade panels considers actions from dead load $F_{Sk,G}$ (permanent action) and wind $F_{Sk,w}$ (leading variable action)

HFB Fixing for GRC and concrete stone panels	Annex B1 of European Technical Assessment ETA-18/1001
Intended use - Specification	

Table C1 Characteristic values for the design of the anchor and façade panel

Characteristic values of facade panel	panel thickness		$h =$	mm	20 -0,5/+1,0
	characteristic resistance to bending stress		$\sigma_{rk, 5\%} =$	N/mm ²	2,9
	characteristic resistance to breakout or pull-out failure under tension load				NPA
	characteristic resistance to breakout or pull-out failure under shear load				NPA
	Characteristic resistance to breakout or pull-out failure under combined tension and shear load				NPA
	partial safety factor ¹⁾ façade panel		$\gamma_M =$	-	1,44
	modulus of elasticity		$E =$	N/mm ²	10.000
	thermal coefficient		$\alpha_T =$	1/K	1-1,5 ×10 ⁻⁵
	Specific weight		$\gamma =$	kN/m ³	21
Characteristic values of the anchor	characteristic resistance to	tension load ²⁾	$N_{rk,5\%} =$	kN	Single pad: 1,95 Double pad: 2,34
		shear ²⁾	$V_{rk,5\%} =$	kN	Single pad: 3,12 Double pad: 4,95
	Embedment depth		$h_s =$	mm	15 - 25
	Edge distance ³⁾		a_{rx} or $a_{ry} \geq$	mm	100
	Spacing		a_x or $a_y \geq$	mm	200 ⁴⁾
	partial safety factor ¹⁾		$\gamma_M =$	-	1,4

¹⁾ In absence of other national regulations.

²⁾ In case of coincident stress of an anchor due to tension and shear load following equation shall be observed:

$$\frac{N_{Ed}}{N_{Rd}} + \frac{V_{Ed}}{V_{Rd}} \leq 1,0$$

³⁾ For small fitted pieces, differential and fill-in pieces the edge distance and spacing shall be chosen constructively

⁴⁾ The maximum of distance is governed by the load bearing capacity of the panel and determined through the static calculation

HFB Fixing for GRC and concrete stone panels

Characteristic values for the design of the anchor and façade panel

Annex C1
of European
Technical Assessment
ETA-18/1001

Definition of edge distance and spacing

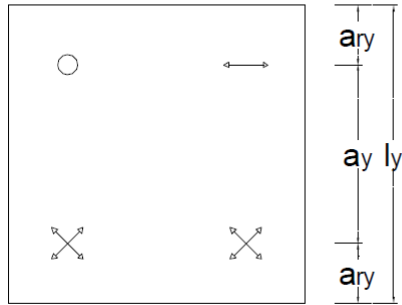
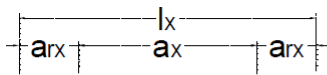

Legend:

- L_x - length of facade panel
- L_y - height of facade panel
- A_x, A_y - distance between anchors
- A_{rx}, A_{ry} - distance between anchor to the panel edge
- fixed point (fixed bearing)
- horizontally sliding point
- horizontally and vertically sliding point

Torsion of the load-bearing profile due to dead loads of the façade panel

In case of flush fixing of the anchor and when using horizontal load-bearing profiles:

Due to torsion of the load-bearing profile resulting from dead load of the façade panel the following load $N_{Sk,v}$ shall be considered in direction to the anchor axes:

$$N_{v,Ek} = V_{Ek} \cdot 2e/c_H$$

Where

V_{Ek} = shear load due to dead load of the façade panel

e and c_H [mm] see figure

M shear centre

HFB Fixing for GRC and concrete stone panels	Annex C2 of European Technical Assessment ETA-18/1001
Definition of edge distance and spacing Torsion of load-bearing profile	